



V-Plow

For

Skid Steer Loaders

Operator's Manual
Maintenance
Parts Information



Read this Manual Before Use

TABLE OF CONTENTS

SAFETY	3-4
SERIAL NUMBER/DECAL LOCATION	5-6
USER'S MOUNTING INSTRUCTIONS	7-8
OPERATING INSTRUCTIONS	9
ROUTINE MAINTENANCE	10-11
PARTS INFORMATION	12-15
GENERAL SPECIFICATIONS	16
BOLT TORQUE INFORMATION	17
NOTES	18
WARRANTY	19

REFERENCE INFORMATION

Write the serial number for your attachment in the spaces below. Always refer to this serial number when calling for service or parts.

Serial Number....._____

YOUR ATTACHMENT DEALER

ADDRESS:

PHONE:

CONTACT:

NOTE: *Erskine Attachments LLC reserves the right to make improvements in design or changes in specifications at any time without notice and without incurring any obligations to install them on units previously sold.*

SAFETY

DO NOT use or perform maintenance on this machine until this manual has been read and understood. In addition, read the Operation and Maintenance Manual(s) pertaining to the attachment and the attachment carrier (“Loader”).

The user is responsible for inspecting the machine daily, and for having parts repaired or replaced when continued use of the machine would cause damage, excessive wear to other parts or make the machine unsafe for continued operation.

If an operating procedure, tool device, maintenance or work method not specifically recommended is used, you must satisfy yourself that it is safe for you and others. You must also ensure that the attachment will not be damaged or made unsafe by the procedures you choose.

Erskine Attachments LLC cannot anticipate every possible circumstance that might involve potential hazard. The safety messages found in this manual and on the machine are therefore not all inclusive.

Throughout this manual, reference may be made to the left hand (LH) and right hand (RH) side. These terms are used as viewed from the operator’s seat facing front.

The signal words **CAUTION**, **WARNING**, or **DANGER** are used to indicate hazards.

⚠ CAUTION Indicates a potentially hazardous situation which, if not avoided, may result in minor or moderate injury.

⚠ WARNING Indicates a potentially hazardous situation which, if not avoided, could result in death or serious injury.

⚠ DANGER Indicates a potentially hazardous situation which, if not avoided, will result in death or serious injury.

The word **IMPORTANT** is used in the text when immediate damage will occur due to improper technique or operation.

The word **NOTE** is used to convey information that is out of context with the manual text; special information such as specifications, techniques, reference information, and other information of a supplementary nature.

Improper operation can cause serious injury or death.

Pre-operation

- This machine is designed for moving snow only. **NEVER** use this machine for any other purpose.
- Read the operator's manual for the "Skid Steer Loader." **NEVER** allow untrained people to operate.
- Operating instructions must be given to everyone before operating this attachment and at least once a year thereafter in accordance with OSHA regulations.
- **NEVER** exceed the maximum recommended input power or speed specifications for the attachment. Over-powering or over-speeding the attachment may cause personal injury and/or machine damage.
- Keep all shields, guards, and covers in place.
- Do not modify equipment or add attachments that are not approved by Erskine Attachments LLC.
- Use adequate safety warning lights and devices as required by local regulations. Obey all local laws and regulations regarding machine operation on public property.

Operation

- Hydraulic connections may be hot after use. Use gloves if connecting or disconnecting after use.
- Check and be sure all operating controls are in neutral before starting the engine.
- Keep people away from loader and attachment when in use. This attachment has moving parts.
- Always stay in the operator's position when using the attachment.

Operation (continued)

- **NEVER** operate near embankments or terrain that is so steep that rollover could occur.
- Before leaving the operator's position, lower the attachment to rest flat on the ground, stop engine, relieve hydraulic pressure to the attachment, set park brake, and wait for all motion to stop.
- **NEVER** place hands near moving parts or clear debris while engine is running.

Avoid High Pressure Fluids Hazard



- Escaping fluid under pressure can penetrate the skin causing serious injury.
- Avoid the hazard by relieving the pressure before disconnecting hydraulic lines.
- Use a piece of paper or cardboard, NOT BODY PARTS, to check for suspected leaks. Wear protective gloves and safety glasses or goggles when servicing or performing maintenance on hydraulic systems.
- If an accident occurs, see a doctor immediately. Any fluid injected into the skin must be surgically removed within a few hours or gangrene may result.

Maintenance

- **NEVER** make adjustments, lubricate, clean, or perform any service on the machine while it is in operation.
- Make sure the attachment is serviced on a daily basis. Improper maintenance can cause serious injury or death in addition to damage to the attachment and/or your equipment.

SERIAL NUMBER AND SAFETY DECAL LOCATIONS

Serial Number Location:

It is important to refer to the serial number of the attachment when making repairs or ordering parts. Early or later models (identification made by serial number) may use different parts, or it may be necessary to use different procedures in doing a specific operation.

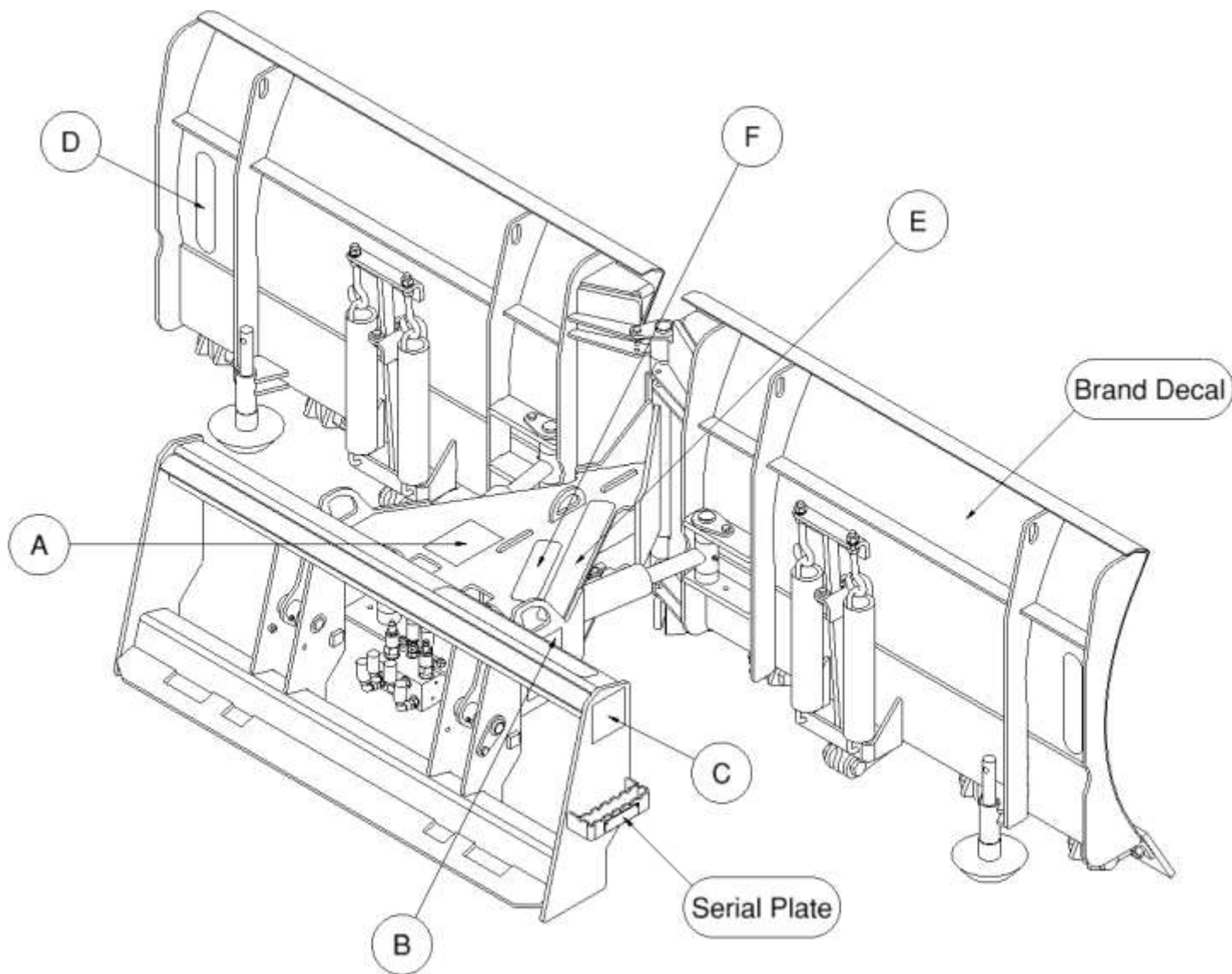

SERIAL NUMBER AND SAFETY DECAL LOCATIONS



Part number: 200001

Location: On top of pivot frame

Quantity: 1



Part number: 203234

Location: On each side of pivot frame

Quantity: 2



Part number: 320025

Location: On each side of mount frame

Quantity: 2

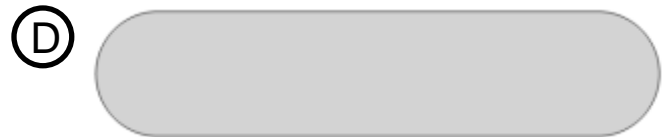

Part number: 300245 (Yellow Reflector)

Location: On back of moldboard, both ends

Quantity: 2



Part number: 202153 (Tape Anti-Skid 2 x 16)

Location: Top of pivot frame & mount frame

Quantity: 2



Part number: 202152 (Tape Anti-Skid 2 x 8)

Location: On top of pivot frame

Quantity: 1

Small Brand Decal

Location: On back of moldboard, both ends

Quantity: 2

Safety Decals Locations:

The locations of the safety decals are shown. If these decals are missing, damaged, or painted over they must be replaced. Call Erskine Attachments LLC (218-435-4045) for replacement decals.

USER'S MOUNTING INSTRUCTIONS

After the initial set-up assembly is completed, use the following procedure to mount the attachment to the loader.

⚠ WARNING Coupler wedges or pins must extend through holes in attachment. Levers must be fully down and locked. Failure to secure wedges or pins can allow the attachment to come off and cause injury or death.

1. Use the step, safety treads, and grab handles to get on and off the loader and attachment.

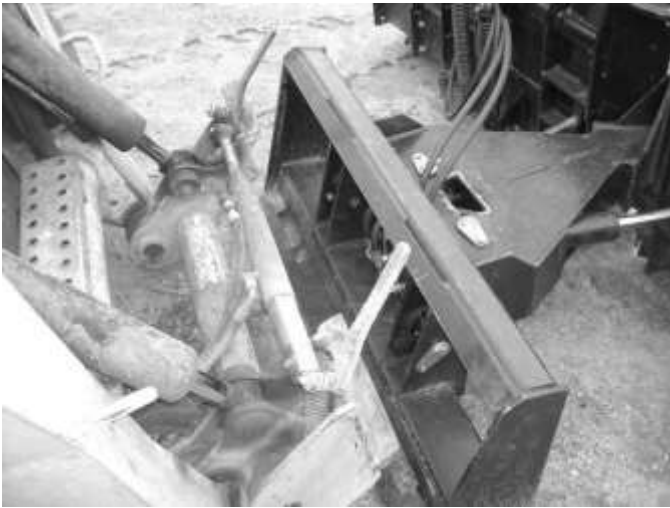

2. Sitting in the operator's seat, lower seat bar (if so equipped) and fasten the seat belt.

3. Drive the loader to the rear of the attachment. Put the loader quick attach coupler into the attachment mounting bracket.



4. Tilt the loader coupler backward a small amount until it is fully engaged in the attachment mounting bracket.

5. Stop the engine and engage the park brake.

6. Secure the coupler locking mechanism that attaches the attachment to the loader.

USER'S MOUNTING INSTRUCTIONS

7. Connect the hydraulic quick couplers from the attachment to the loader.

IMPORTANT: Wipe the ends of the hydraulic quick couplers (both lead and loader) with a rag to remove any possible contamination. Contamination can cause hydraulic components to fail and is not covered under warranty.

IMPORTANT: Make sure the quick couplers are fully engaged. If the quick couplers do not fully engage, check to see that the couplers are the same size and brand. Do not force the quick couplers together.

NOTE: See the loader's operator's manual for auxiliary hydraulic specifications and connection instructions.

NOTE: Attachment is shipped with 8FJX (1/2" Female JIC Swivel) fittings on the ends of the lead hoses.

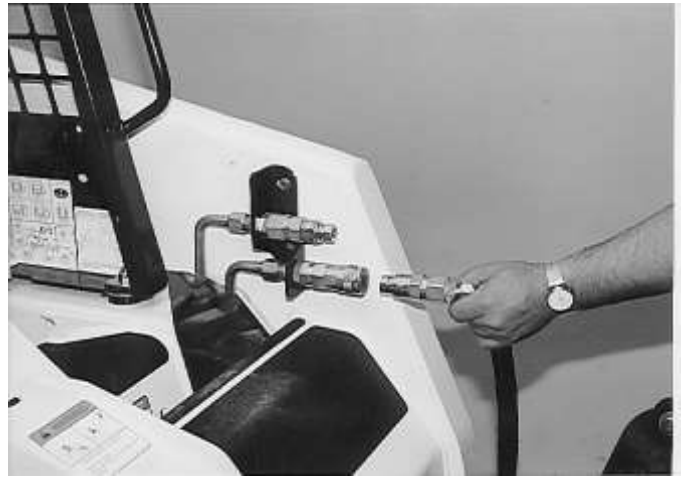

8. Make sure the hoses are properly routed to fit your specific loader. If the hoses are not routed correctly, hoses may get pinched or rub on tires. Be sure to check the hose routing through the full range of intended motion of the attachment before operating it.

More than one routing may be acceptable depending on the loader. Pick the routing that best suits your loader.

IMPORTANT: Proper hose routing is the responsibility of the owner and/or operator. Pinched or stretched hoses are not covered under warranty.

Mounting is now complete and the attachment is ready for operation. Use reverse order of above instructions to dismount the attachment from the loader.

OPERATING INSTRUCTIONS



IMPORTANT: The v-plow is designed for snow removal only. It is not designed for moving or grading soil.

1. With the operator in the seat of the loader, the seat belt fastened, and the seat bar lowered (if so equipped), start the engine.
2. With the loader lift arms fully lowered, tilt the attachment forward to rest on the skid shoes.
3. Drive the loader forward to push snow.
4. Use the loader lift and tilt functions to increase traction and adjust the pitch of the v-plow.

Blade Angle

The v-plow utilizes a specially designed valve block to change the blade orientation without the requirement of an electrical attachment control system. The valve block isolates one side of the attachment as the priority side, with the secondary side moving once the priority side has reached the end of its stroke.

1. Activate the auxiliary hydraulic circuit to move the priority side to the desired position and keep it activated until the secondary side has moved to the desired configuration.
2. To move the blades into a position other than the end of the stroke, activate the auxiliary hydraulic circuit until the secondary side is in the desired position, then reverse the hydraulic flow until the priority side is in the desired position.

NOTE: The blades may have to be repositioned after hard contact with a solid object. This is normal due to the design of the valve block.

Trip Springs

The v-plow is equipped with trip springs which allow the cutting edge to trip when it strikes an obstruction. This helps to protect the attachment and the obstruction from damage.

To reset the trip springs after striking an obstruction, raise the loader lift arms to lift the attachment slightly off of the ground, or slowly drive the loader backward a few feet.

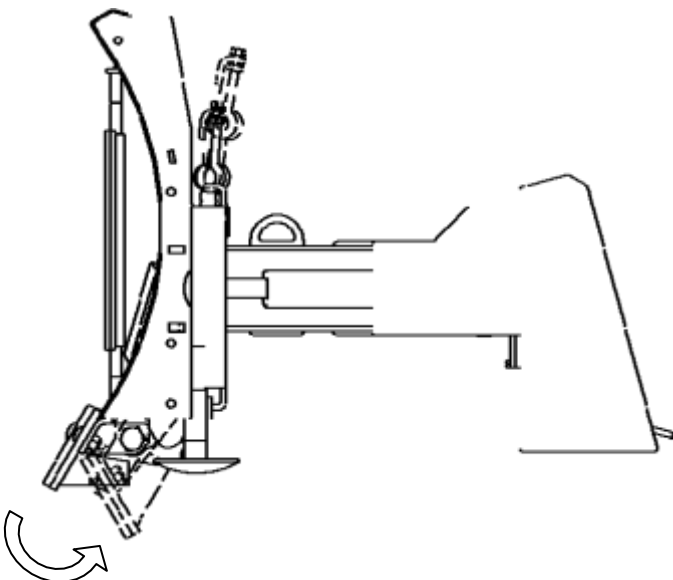
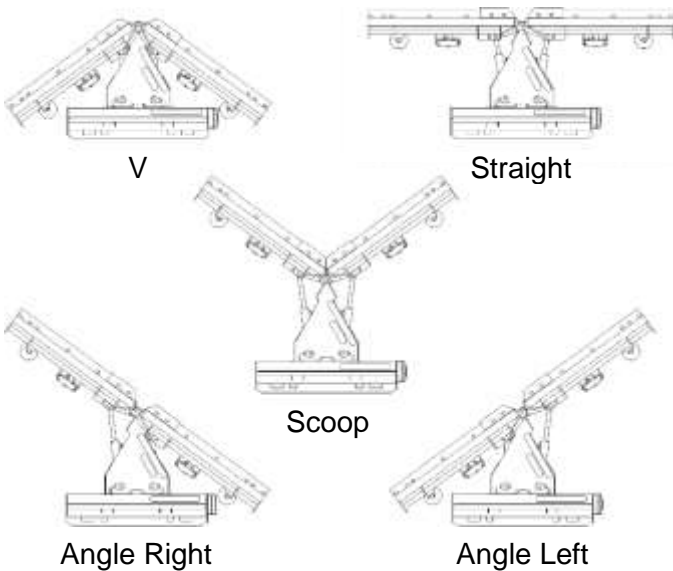





ROUTINE MAINTENANCE

⚠ WARNING Lower the attachment to rest flat on the ground, shut down the engine, relieve the hydraulic pressure to the attachment, set the park brake, and wait for all motion to stop before leaving the operator's seat to perform service of any kind.

It is the operator's responsibility to make daily inspections of the loader and attachment for damage, loose bolts, fluid leaks, or anything else that could cause a potential service or safety problem. Preventive maintenance is the easiest and least expensive type of maintenance.

IMPORTANT: Bolts can loosen after initial usage. After the first hour of operation check all bolts.

LUBRICATION

Lubrication Legend	 Multipurpose spray lube	 No. 2 Lithium base gun grease	 Clean engine oil	 50	Intervals at which lubrication is required
---------------------------	---	---	--	--	--

Use No. 2 lithium base gun grease when lubricating all attachment grease fittings.

	
---	---

Grease both mounting plate pivot bushings [A] every **8 hours** of operation.

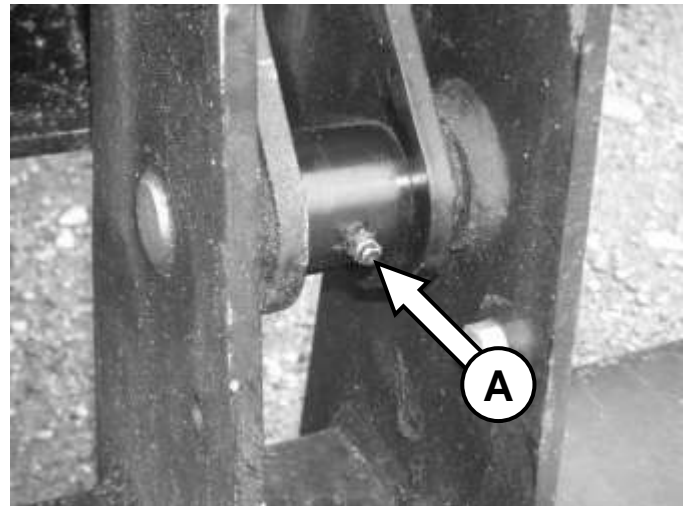

Grease the blade pivot pins (top and bottom) [B] every **8 hours** of operation.

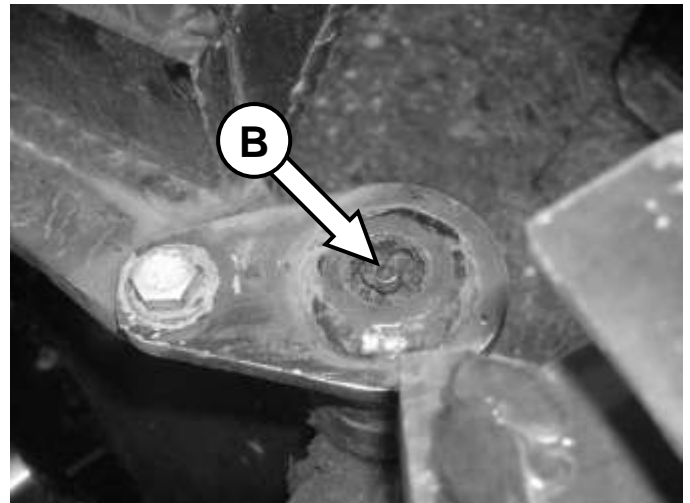

ROUTINE MAINTENANCE

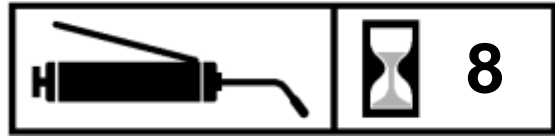
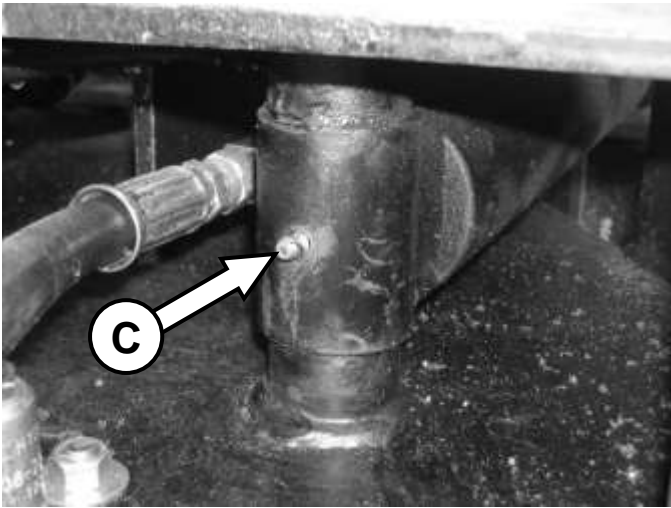

Grease all four cylinder bushings [C] every **8 hours** of operation.

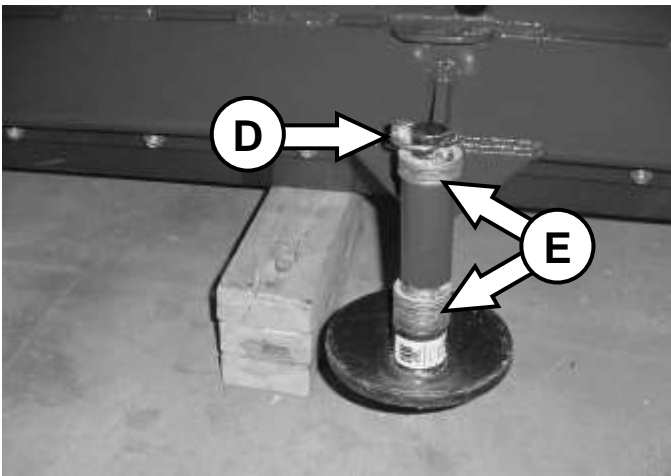
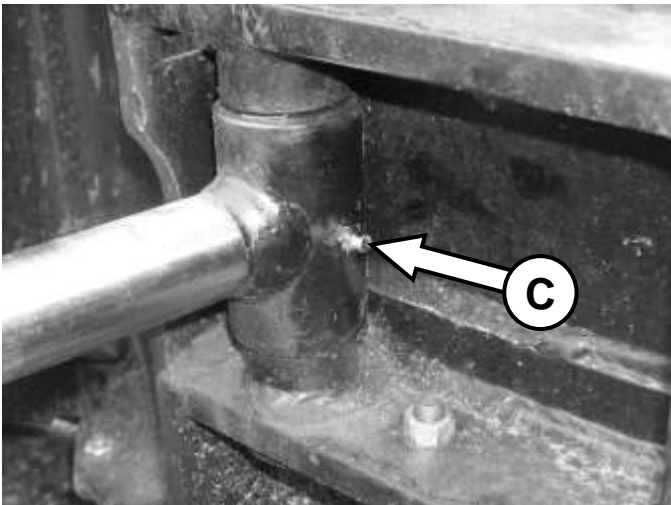

Skid Shoe Height Adjustment

1. Raise the v-plow off of the ground and block up securely.
2. Remove the lynch pin [D] from the first skid shoe and slide the skid shoe out of the mount bushing.
3. Install spacer washers [E] on the skid shoe to achieve the desired cutting edge height, and slide the skid shoe back into the mount bushing.
4. Store remaining spacer washers on top of the mount bushing, and install the lynch pin to secure the skid shoe and washers in place.
5. Repeat steps 2-4 for the other skid shoe. Make sure both skid shoes are set to the same height.

PARTS INFORMATION

ITEM	QTY	PART NO.	DESCRIPTION	STOCK NO.
1	1	311300	MOUNT V-PLOW W/A	
	1	422197	MOUNT V-PLOW MULTIHOG W/A	MULTIHOG MOUNT
2	1	311379	MOLDBOARD V-PLOW 84 LH W/A	USED ON 84"
	1	311381	MOLDBOARD V-PLOW 96 LH W/A	USED ON 96"
	1	311383	MOLDBOARD V-PLOW 108 LH W/A	USED ON 108"
3	1	311380	MOLDBOARD V-PLOW 84 RH W/A	USED ON 84"
	1	311382	MOLDBOARD V-PLOW 96 RH W/A	USED ON 96"
	1	311384	MOLDBOARD V-PLOW 108 RH W/A	USED ON 108"
4	2	311305	SPRING LIFT W/A	
5	4	100303	SPRING TRIP 2.38 OD X 15 EXT	
6	1	311301	PIVOT MOUNT W/A	
8	1	311304	TRIP EDGE 84 W/A	USED ON 84"
	1	300879	TRIP EDGE 96 LH W/A	USED ON 96"
	1	300881	TRIP EDGE 108 LH W/A	USED ON 108"
9	1	311304	TRIP EDGE 84 W/A	USED ON 84"
	1	300880	TRIP EDGE 96 RH W/A	USED ON 96"
	1	300882	TRIP EDGE 108 RH W/A	USED ON 108"
10	2	311306	PIN 1.25 X 6 GREASABLE W/A	
12	2	400041	PIN 1 X 4 W/A	
13	6	13467	BOLT HEX 1 X 3-1/2 NC GR 5	USED ON 84"
	8	13467	BOLT HEX 1 X 3-1/2 NC GR 5	USED ON 96 & 108"
14	2	37217	NUT HEX LOCK	3/4 NC
16	8	103116	BOLT HEX	3/8 X 1 NC GR 5
17	12	37212	NUT HEX LOCK	3/8 NC
18	8	201452	BOLT CARRIAGE 5/8 X 1 1/2 NC GR 5	USED ON 84"
	10	201452	BOLT CARRIAGE 5/8 X 1 1/2 NC GR 5	USED ON 96 & 108"
19	12	37216	NUT HEX LOCK 5/8 NC	USED ON 84"
	14	37216	NUT HEX LOCK 5/8 NC	USED ON 96 & 108"
20	2	100301	SKID SHOE	
22	6	37219	NUT HEX LOCK 1 NC	USED ON 84"
	8	37219	NUT HEX LOCK 1 NC	USED ON 96 & 108"
24	2	311362	BRKT SPRING LIFT HOLDER PAINTED	
25	4	42264	BOLT EYE 1/2 X 4	
26	2	311367	CUTTING EDGE B 1/2 X 6 X 38.56	USED ON 84"
	2	311368	CUTTING EDGE B 1/2 X 6 X 44.56	USED ON 96"
	2	311369	CUTTING EDGE B 1/2 X 6 X 50.56	USED ON 108"
27	4	21834	BOLT CARRIAGE	5/8 X 2 NC GR 5
28	2	13365	BOLT HEX	3/4 X 3 NC GR 5
29	8	33626	WASHER LOCK	1/2
30	8	36110	NUT HEX REG	1/2 NC
31	4	13107	BOLT HEX	3/8 X 1 1/4 NC GR 5
35	1	311364	CUTTING EDGE CENTER LH PAINTED	
36	1	311366	CUTTING EDGE CENTER RH PAINTED	
43	4	312104	PIN 1.25 X 6 W/A	
44	2	300086	SKID SHOE 6" HEAVY-DUTY	OPT HARDENED PKG

PARTS INFORMATION

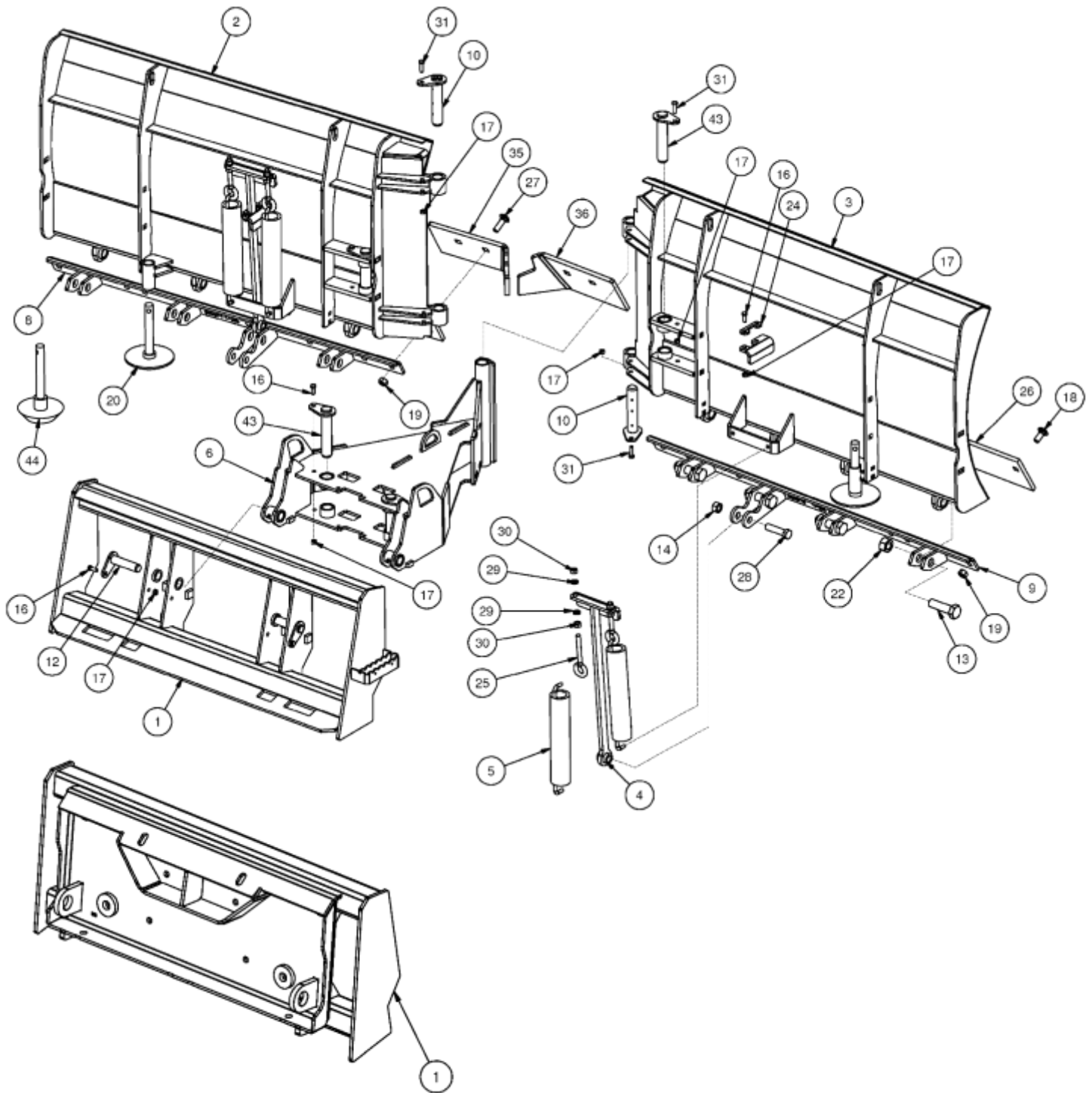

PARTS INFORMATION

ITEM	QTY	PART NO.	DESCRIPTION	STOCK NO.
1	2	311370	CYLINDER 2" X 10" B-B	
2	1	311371	VALVE BLOCK	
3	2	311373	HOSE 3/8 X 80 8FJX-6FJX	LEAD
4	4	320089	ADPT ELB 8MB-6MJ-90	
5	2	311374	HOSE 3/8 X 13 6FJX-6FJX90	CYL BASE TO A2 & B2
6	2	311375	HOSE 3/8 X 25 6FJX-6FJX90	CYL ROD TO A1 & B1
7	5	311673	ADPT STR 6MB-6MJ	
8	1	300657	ADPT STR RESTRICTOR 6MB-6MJ-1/16	
9	2	13116	BOLT HEX	3/8 X 3-1/4 NC GR5
10	2	37212	NUT HEX LOCK	3/8 NC

PARTS INFORMATION

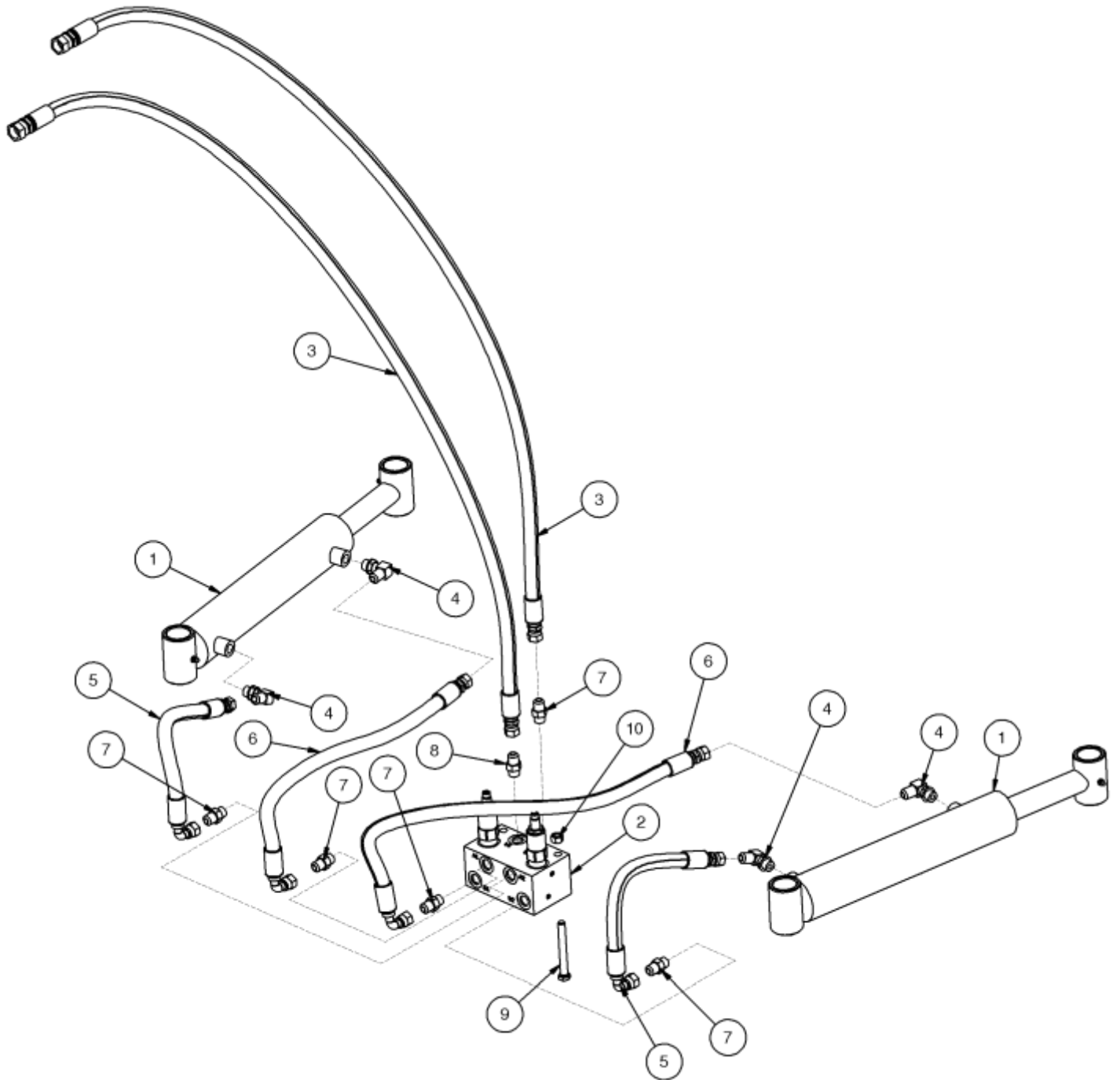

GENERAL SPECIFICATIONS

Model	84	96	108
A) Straight Blade Width	86"	98"	110"
B) Angled Blade Width	69"	79"	89"
C) V Position Width	75"	85"	96"
D) Scoop Position Width	63"	73"	81"
E) Blade Height	31.8"		
F) Blade Angle	$\pm 36^\circ$		
G) Mount Flotation	$\pm 2.5^\circ$		
H) Overall Length	41.75"		
Moldboard Thickness	0.135"		
Cutting Edge	1/2" x 6" Bolt-On		
Operating Weight	825 lbs.	875 lbs.	920 lbs.

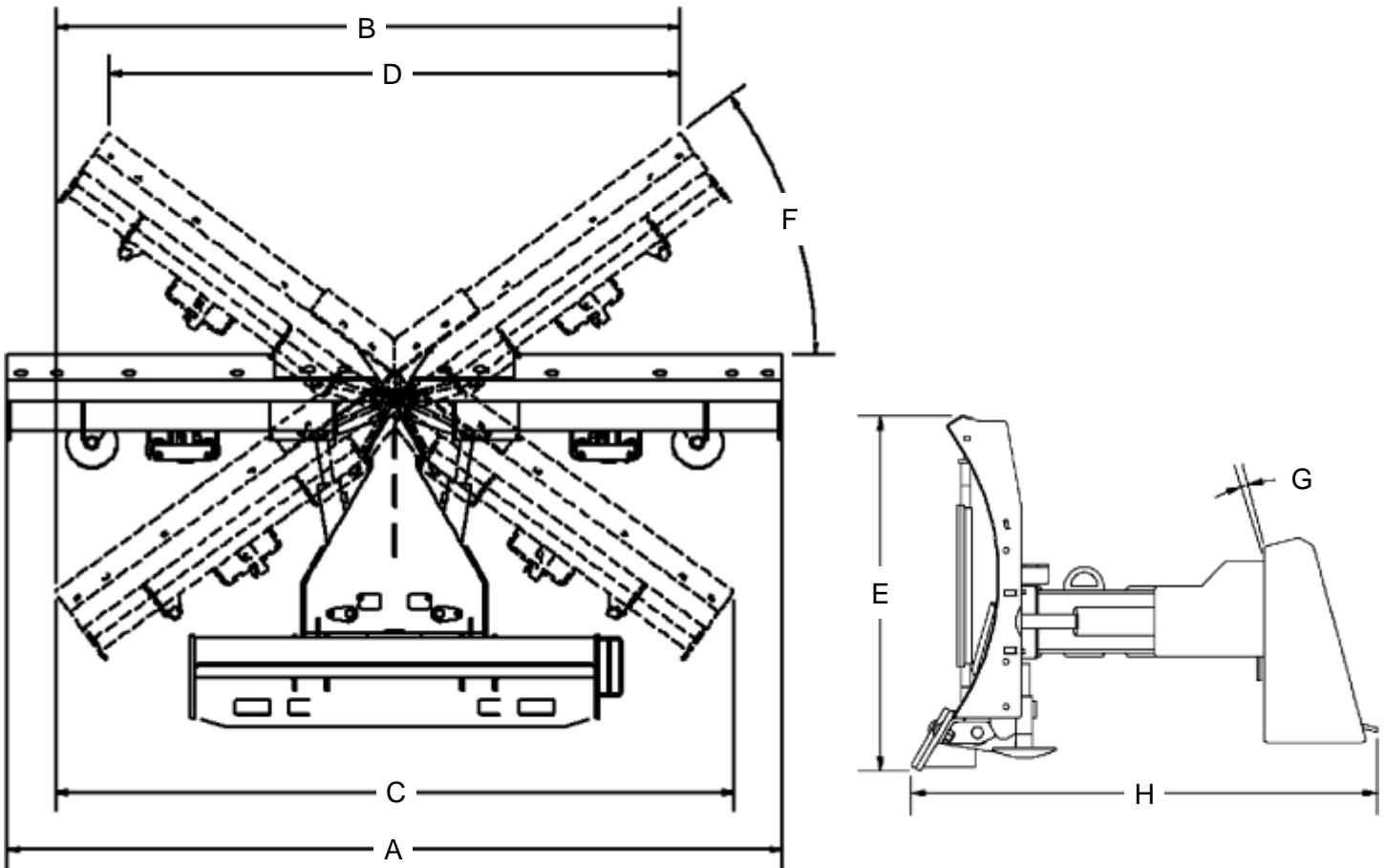

All dimensions are in INCHES.

BOLT TORQUE INFORMATION

Torque-Tension Relationships for SAE J429 Grade Bolts

Nominal Thread Size	SAE J429 Grade 2			SAE J429 Grade 5			SAE J429 Grade 8		
	Clamp Load (lbs)	Tightening Torque		Clamp Load (lbs)	Tightening Torque		Clamp Load (lbs)	Tightening Torque	
		K = .15	K = .20		K = .15	K = .20		K = .15	K = .20
Unified Coarse Thread Series									
1/4-20	1,300	49 in-lbs	65 in-lbs	2,000	75 in-lbs	100 in-lbs	2,850	107 in-lbs	143 in-lbs
5/16-18	2,150	101	134	3,350	157	210	4700	220	305
3/8-16	3,200	15 ft-lbs	20 ft-lbs	4,950	23 ft-lbs	31 ft-lbs	6,950	32.5 ft-lbs	44 ft-lbs
7/16-14	4,400	24	30	6,800	37	50	9,600	53	70
1/2-13	5,850	36.5	49	9,050	57	75	12,800	80	107
9/16-12	7,500	53	70	11,600	82	109	16,400	115	154
5/8-11	9,300	73	97	14,500	113	151	20,300	159	211
3/4-10	13,800	129	173	21,300	200	266	30,100	282	376
7/8-9	11,425	125	166	29,435	321	430	41,550	454	606
1-8	15,000	187.5	250	38,600	482.5	640	54,540	680	900
Unified Fine Thread Series									
1/4-28	1,500	55 in-lbs	75 in-lbs	2,300	85 in-lbs	115 in-lbs	3,250	120 in-lbs	163 in-lbs
5/16-24	2,400	112	150	3,700	173	230	5,200	245	325
3/8-24	3,600	17 ft-lbs	22.5 ft-lbs	5,600	26 ft-lbs	35 ft-lbs	7,900	37 ft-lbs	50 ft-lbs
7/16-20	4,900	27	36	7,550	42	55	10,700	59	78
1/2-20	6,800	41	55	10,200	64	85	14,400	90	120
9/16-18	8,400	59	79	13,000	92	122	18,300	129	172
5/8-18	10,600	83	110	16,300	128	170	23,000	180	240
3/4-16	15,400	144	193	23,800	223	298	33,600	315	420
7/8-14	12,610	138	184	32,480	355	473	45,855	500	668
1-12	16,410	205	273	42,270	528	704	59,670	745	995

Clamp load estimated as 75% of proof load for specified bolts.

Torque values for 1/4 and 5/16 inch series are in inch-pounds. All other torque values are in foot-pounds.

Torque values calculated from formula $T = KDF$

where: $K=0.15$ for "lubricated" conditions

$K=0.20$ for "dry" conditions



LIMITED WARRANTY

Erskine Attachments LLC warrants each new machine manufactured by us to be free from defects in material and workmanship for a period of twelve (12) months from date of delivery to the original purchaser.

Our obligation under this warranty is to replace free of charge, at our factory or authorized dealership, any part proven defective within the stated warranty time limit.

All parts must be returned freight prepaid and adequately packaged to prevent damage in transit.

This warranty does not cover:

1. New products which have been operated in excess of rated capacities or negligence
2. Misuse, abuse, accidents or damage due to improperly routed hoses
3. Machines which have been altered, modified or repaired in any manner not authorized by our company
4. Previously owned equipment
5. Any ground engaging tools in which natural wear is involved, i.e. tooth tips, cutting teeth, etc
6. Normal maintenance
7. Fork tines
8. Hydraulic motors that have been disassembled in any manor

In no event will the Sales Representative, Dealership, Erskine Attachments LLC, or any other company affiliated with it or them be liable for incidental or consequential damages or injuries, including but not limited to the loss of profit, rental or substitute equipment or other commercial loss. Purchaser's sole and exclusive remedy being as provided here in above.

Erskine Attachments LLC must receive immediate notification of defect and no allowance will be made for repairs without our consent or approval.

This warranty is in lieu of all other warranties, express or implied by law or otherwise, and there is no warranty of merchantability or fitness purpose.

No agent, employee, or representative of Erskine Attachments LLC has any authority to bind Erskine Attachments LLC to any warranty except as specifically set forth herein. Any of these limitations excluded by local law shall be deemed deleted from this warranty; all other terms apply.

This warranty may not be enlarged or modified in any manner except in writing signed by an executive officer of Erskine Attachments LLC to improve its products whenever it is possible and practical to do so. Erskine Attachments LLC reserves the right to make changes and or add improvements at any time without incurring any obligation to make such changes or add such improvements to products previously sold.

Erskine Attachments LLC
P.O. Box 1083 Alexandria, MN 56308
Phone (218) 435-4045 Fax (218) 435-5293



P/N 311377
Erskine Attachments LLC

Date Printed: 11/13/2018

Printed in U.S.A.